

CL3TA

3T Integrated MRI Receive Coil Feed Board with Dog-EarSuppressions

General Description

The CL3TA is an integrated 3T magnetic resonance imaging (MRI) receiving coil feed board assembly featuring gain peak suppressions, the **patented (US Patent No. 11,555,875)** dog-ears suppression technology for suppressing the gain peaks up to 10 dB. The feed board contains (1) integrated Lattice Balun which provides common mode suppression and impedance transformation, (2) low input impedance preamp, (3) preamp input protection, and (4) coil de-tune circuitries. The very large noise circles of the preamp allow a variety of coil types with little compromise on SNR. Simply connect a coil loop and an output signal cable to complete the design of each high-performance coil channel.

Key Features

- For 3T MRI frequency of 127.7 MHz
- Designed for 4 Ω to 10 Ω coil loop impedance
- Gain peaks suppression: 10 dB
- Blocking impedance: 600 Ω minimum
- Common mode suppression: 45 dB
- Recovering speed: 2 μ S
- Integrated lattice balun
- Built-in low input impedance preamp
- Preamp noise figure: 0.25 dB
- Coil de-tune control port provided
- Maximum input MRI TX power between Co- and Co+: 47 dBm
- Non-magnetic
- RoHS compliant
- Made in USA

Ordering: CL3TA

Block Diagram

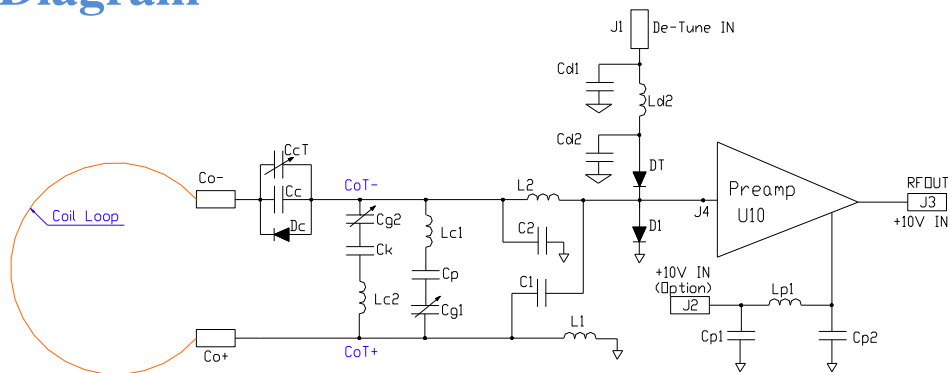

Absolute Maximum Ratings ^[1]

- 47 dBm Maximum input MRI TX power between Co+ and Co- (with coil detune activated)
- +12V DC voltage (V_{dd})
- +20V De-tune voltage (V_{dt}) with a pull-up resistor of 100 Ω in series
- 2KV ESD human body model
- \pm 250 mA De-tune current (I_{dt})
- Operating temperature: +10 $^{\circ}$ C ~ +60 $^{\circ}$ C
- Storage temperature: -40 $^{\circ}$ C ~ +85 $^{\circ}$ C

[1] Operating beyond these limits may cause permanent damages.

Electrical Performance

Parameter	Conditions	Min	Typical	Max	Unit
P_{IN}	127.7 MHz, TX signal, detuned, between Co+ and Co-			47	dBm
G_{sp}	Gain peak suppression	5	10		dB
Z_B	Blocking impedance, ports CoT+ and CoT-	600	1100		Ω
S_{co}	Common mode suppression at 127.7 MHz, ports CoT and input of preamp (J4)	40	45		dB
G_A	Preamplifier gain at 127.7 MHz		28		dB
NF_A	Preamplifier noise figure at 127.7 MHz		0.25		dB
Z_A	Preamplifier input impedance at 127.7 MHz		0.5		Ω
S_{22}	Output return loss at 127.7 MHz	20			dB
OIP_3	Output IP ₃ , -3.0 dBm each tone, 1 MHz separation	18	22		dBm
$P_{0.1dB}$	Output power 0.1 dB compression point	0	3		dBm
P_{1dB}	Output power 1 dB compression point	7	10		dBm
T_r	Recovering speed, 20 dBm @ input		2	4	μ S
I_{DD}	Current consumption		17		mA
V_{DD}	Power supply voltage	+7	+10	+12	V
V_{DT}	Positive detune step control signal, with pull-up 100 Ω resistor in series		+15	+20	V
I_{DT}	Positive detune step control signal, with pull-up 100 Ω resistor in series			250	mA
T_O	Operating temperature	+10		+60	$^{\circ}$ C
T_S	Storage temperature	-40		+80	$^{\circ}$ C

Performance and Application

A. Cc/Cc1/CcT Selection

As shown in the [Block Diagram](#), a coil loop can be connected between Co+ and Co- ports. The loop and on-board Cc, Cc1 and CcT together resonate at 127.7 MHz (3T MRI resonant frequency). Depending on the length or equivalent inductance of the loop, Cc may vary to achieve 127.7 MHz resonance for the loop; The default CcT is 5 ~ 30 pF and can be trimmed accordingly by the user.

B. Detuning (TX Decoupling)

The coil detuning is done by turning on the diode Dc for shorting Cc. The detune signal is applied at port J1 during the TX transmission cycle. The diode Dc is turned on through the DC path and inductor L0 to ground without going through coil loop.

For the negative de-tuning signal, Dc, DT, and D1 polarities need to be reversed. **Let the factory know so that the diodes can be installed correctly.**

The current limiting resistor or pull up resistor is required to limit the de-tuning current. The maximum de-tuning path average current is 250 mA. Without the limiting resistor, the RF choke in the de-tuning path will be damaged.

With the applied detune signal, the diodes D1 and DT are turned on which makes very high TX blocking impedance at the Co+ and Co- during the transmission cycle.

Improper detuning can cause preamp failure by the TX signal.

C. Dog-Ears Gain Peaks Suppression

Fig. 1 is the measurement results of a traditional single coil channel with (Blue) and without (Green) the dog-ears suppression. The 2 gain peaks or dog-ears, at the frequencies of f_L and f_H have about 15 dB higher gain than that at the MR frequency, f_M . The blue curve illustrates the suppressed gain peaks but without sacrificing the gain at the MR frequency.

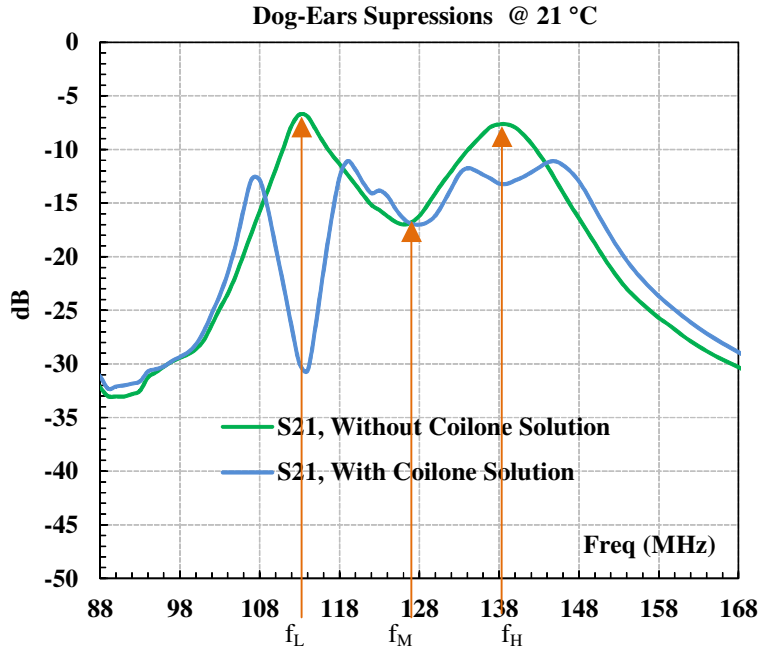

Fig. 1 Dog-Ears Suppression

D. Common Mode Suppression

Typical 45 dB common mode suppression at 127.7 MHz can be achieved. Fig. 2 is a typical measured suppression performance of CL3TA.

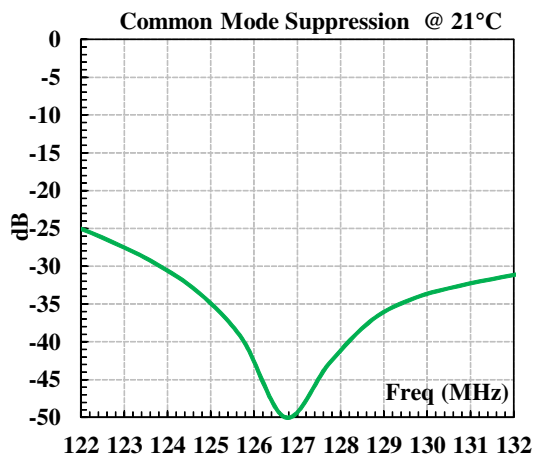

Fig. 2 Common Mode Suppression

E. Blocking Impedance

Typical 1.2 k Ω Blocking Impedance at 127.7 MHz can be achieved. Fig. 3 is a typical measured Blocking Impedance performance of CL3TA.

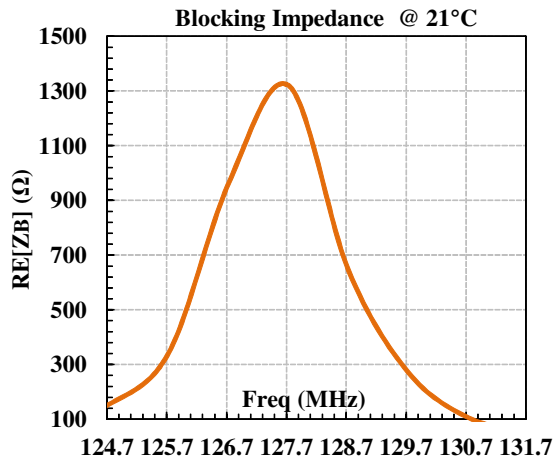
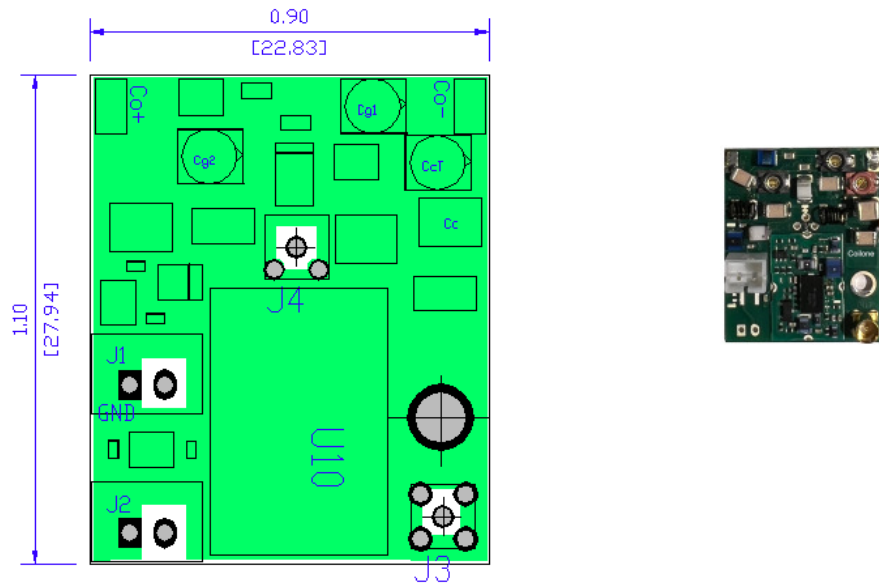

Fig. 3. Blocking Impedance Z_B

F. Coil Loop Selection

CL3TA leaves the coil designer with easy high performance coil design. Any type of coil loops can be used. Very large noise circles of integrated on board preamp forgive the large source impedance variation caused by the coil loop without degrading SNR. Flexible loops, wire loops, etc. are suitable as long as loops resonate at the MRI frequency of 127.7 MHz with the on board capacitors, Cc and CcT.

G. Outline



J1/J2(Optional): 2.0 mm pitch/Disconnectable Crimp Style Connector

Part Number: B2B-PH-K-S(LF)(SN) or equivalent

J3: PCB Mount MMCX Connector, Straight Jack

J4: Testing Port

PCB Material: FR-4

Unit: Inch

[mm]

Tolerance: X.XX ±0.01